

# Acoustic coupling and directivity control

Ing. C. DEMARD  
PIERRARD – Virton

*This article deals with the kind of acoustic sources, how waves propagate and the criteria which allow to couple sources. It also explains why and how to control the directivity, as well as what is a bad directivity (with real examples). Designing such a product requires knowledge of mechanical manufacturing, electronics, acoustics, design, etc. There is not a “recipe” to design a professional soundsystem because applications are wide. Directivity is just one problem and criteria out of many. Another goal of this article is to explain few of many problems while designing a professional soundsystem.*

*Keywords: acoustic, source, directivity, line array.*

*Cet article traite des types de sources acoustiques, de la manière dont les ondes se dispersent et les critères du couplage acoustique. Il explique également pourquoi et comment contrôler la directivité d'une source, tout en s'appuyant sur des exemples pratiques. Concevoir un tel produit requiert des connaissances dans de nombreux domaines : fabrication mécanique, électronique, acoustique, design, etc. Il n'existe pas une “recette” à suivre pour élaborer une enceinte professionnelle car les applications sont trop variées. La directivité d'une enceinte est un problème et un critère parmi beaucoup d'autres. Un autre but de cet article est de présenter quelques uns des problèmes rencontrés lors de la conception d'une enceinte acoustique professionnelle.*

*Mots-clefs : acoustique, source, directivité, line array.*

## 1. Introduction

Acoustic coupling theory has been used from a long time. Line array is the well-known application. A line array is an array of speakers. Each speaker is a point source and the line array tries to be a line source, so that each speaker is acoustically coupled with the other one. Dr Heil gave an analogy to illustrate this concept. « *Imagine when you throw a stone in a lake. This creates a progressing circular wave from the drop point. If you throw several stones, there is an interference network composed of constructive and destructive interference. If you group all the stones in a bag and throw it, again there is a progressing circular wave with higher amplitude.* » [1]. Actually, fundamentals of acoustic coupling have been discovered more than 60 years ago. But the first line array as we know it just appeared in 1992.

## 2. Acoustic Coupling Fundamentals

### 2.1. Point Source

A source is considered as a point while its dimensions are very small compared to the wavelength. Thus, we can apply the model of the point source at low frequencies. However, while the wavelength is close to the diaphragm's diameter, the loudspeaker becomes directive. Therefore the plane piston source model (Figure 1) is closest to the reality. When the loudspeaker moves back and forth, 2 fields appear. In the Near Field, the sound pressure level is constant. The length of the Near Field  $L$  depends on the diaphragm's diameter and the frequency. Higher is the frequency, higher is the throw. In reality, air absorption counteracts this phenomenon. [2]

$$L = \frac{D^2 \cdot f}{2 \cdot c}$$

where  $D$  = diameter of the plane piston source [m],  
 $f$  = frequency [Hz],  
 $c$  = sound speed [m/s].

In the Far Field, the sound pressure level evolves as the point source model. The loss between  $r$  and  $2r$  is determined with the Inverse Square Law. The sound pressure level decreases by 6 dB while the distance has doubled:

$$20 \log \frac{2r}{r} = 6 \text{ dB}$$

The angle  $\theta$  represents the loudspeaker directivity. Out of this angle, the sound pressure level loss is higher than 6 dB. That means the sound pressure level out of this zone is too low for good intelligibility. [2]

$$\theta = 2 \cdot \sin^{-1} \left( \frac{1,22 \cdot c}{D \cdot f} \right)$$

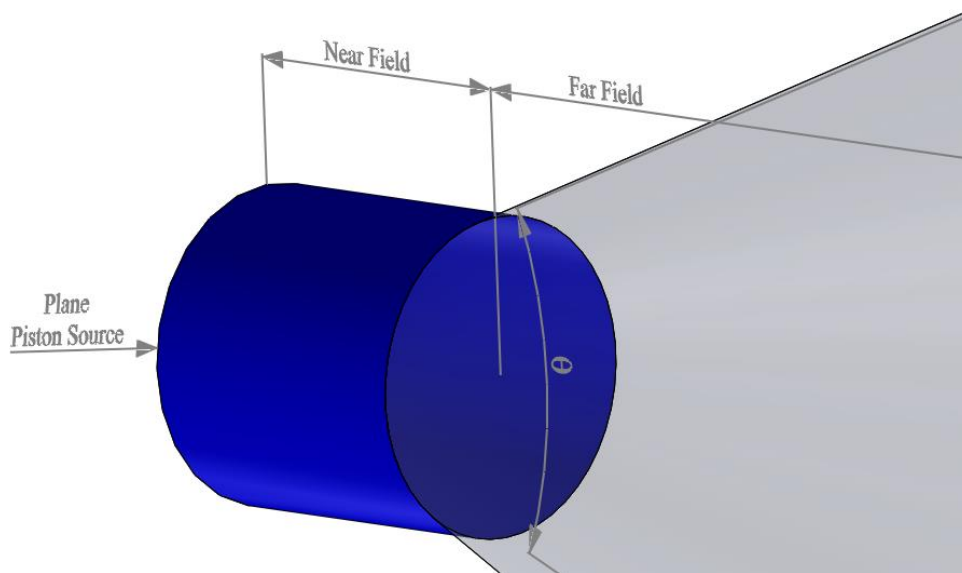

Figure 1 : Plane piston source model.

## 2.2. Line Source

A source is considered as a line while its width  $l$  is low compared to its height  $h$ . When the rectangular piston source radiates (Figure 2), the Near Field also appears. Then a new zone arises, the Intermediate Field, where waves are cylindrical. Thus, the sound pressure level decreases by only -3 dB while the distance has doubled. After that, waves become spherical (-6 dB while distance has doubled). But the Intermediate Field appears with at least 2m line. If the line is too short, the source radiates as a plane piston. [2]

The radius of the Intermediate Field  $R$  (that means the length) is found by:

$$R = \frac{h^2 \cdot f}{2 \cdot c}$$

The horizontal directivity is found by :

$$\theta_h = 2 \cdot \sin^{-1}\left(\frac{1,22 \cdot c}{l \cdot f}\right)$$

For the vertical directivity :

$$\theta_v = 2 \cdot \sin^{-1}\left(\frac{1,22 \cdot c}{h \cdot f}\right)$$

For example, a line source which is 1m wide has an horizontal directivity of 62° at 800 Hz. If it is 10m high, it has a vertical directivity of 6° at 800 Hz.

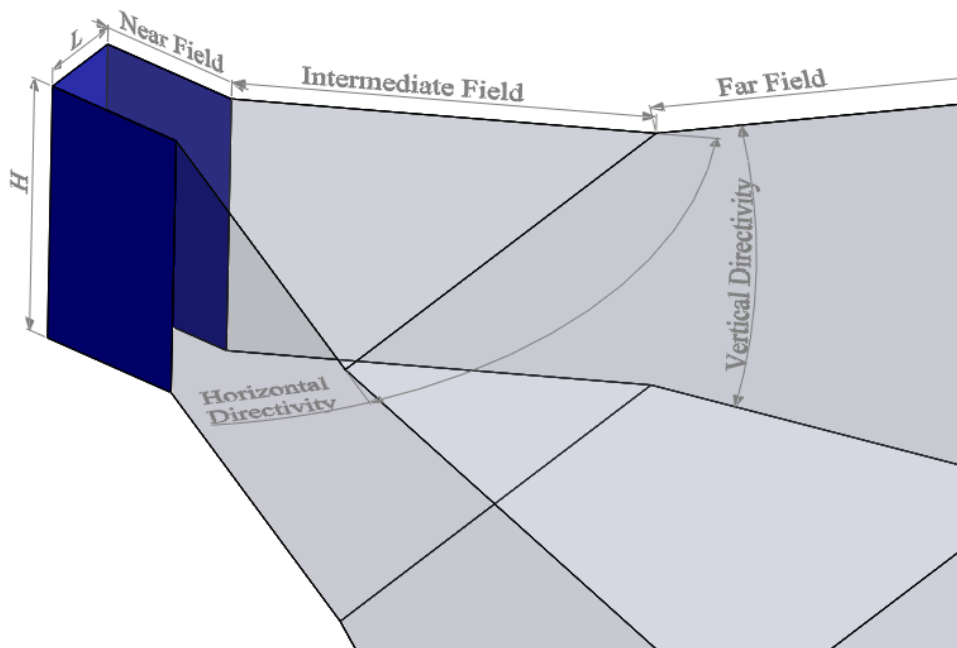

Figure 2 : Line Source model.

### ***Straight line array***

If all the speakers are rigged without any angle, the line array is straight (Figure 3). It is very rare to use this kind of configuration, because most of the energy is radiated on the centre of the array. Thus, the sound pressure level is not homogeneous through the audience. On Figure 4, there is a simulation of such a setup. The black curve which crosses tags is the averaging sound pressure level. It is not flat, there are many dips which mean the level is not homogeneous over the audience.



Figure 3 : Straight array of 16 boxes.

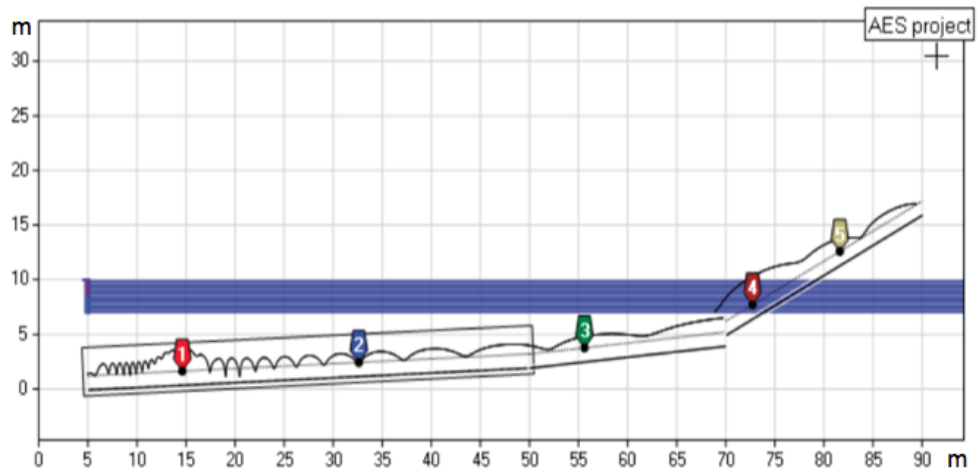

Figure 4 : Example of application of a straight line array to a typical large-scale arena. [3]

### *J-shape*

Curving the line array (Figure 5) allows to spread the energy over the audience, according to the venue. Indeed, the averaging sound pressure level for a J-shape line array is flatter (Figure 6).

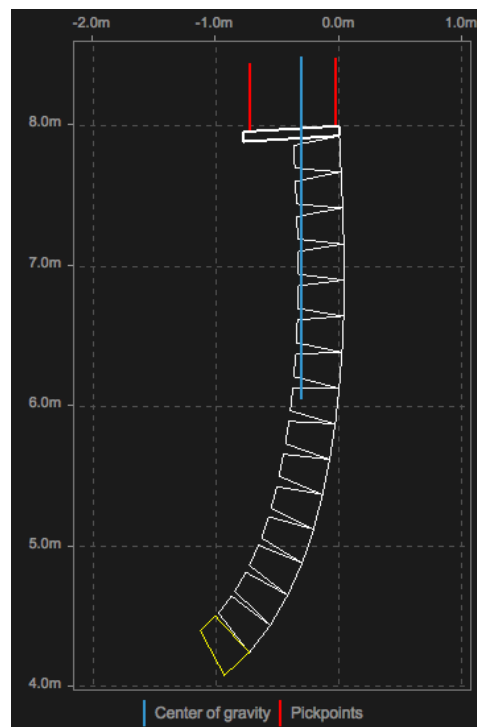

Figure 5 : J-array of 16 boxes.

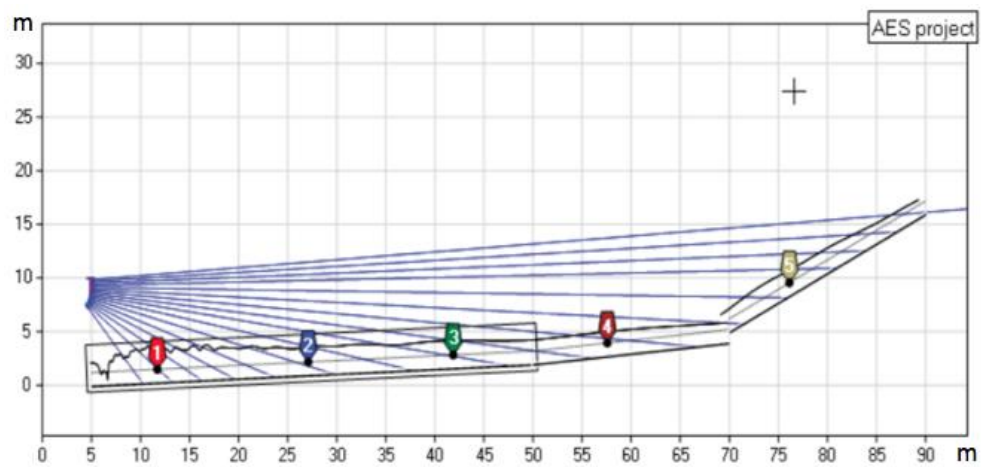

Figure 6 : Vertical system configuration relative to the arena example [3].

## 2.3. Acoustic Coupling Criteria

### *Half of wavelength*

The spacing between the acoustic centre of each sound source should be smaller than  $\lambda/2$  at the highest operating frequency. For example, if 2 loudspeakers reproduce frequencies until 1 kHz, the maximum step between their centres should be:

$$\frac{c}{2 \cdot f} = \frac{340}{2 \cdot 1000} \approx 17 \text{ cm}$$

### *Waveguide requirements*

It is tricky to fill the «  $\lambda/2$  criteria » for high frequencies, since wavelength become very short. This is why the waveguide has been created. There are many kinds of waveguides (see Figure 7).



Figure 7 : Examples of waveguides. Manifold waveguide on the left and conical waveguide on the right. [4]

They all work differently but they have the same target: getting a flat wavefront at the output. It is allowed that the deviation  $s$  (Figure 8) from a flat wavefront should be less than  $\lambda/4$  at the highest operation frequency (corresponding to 5 mm at 16 kHz).

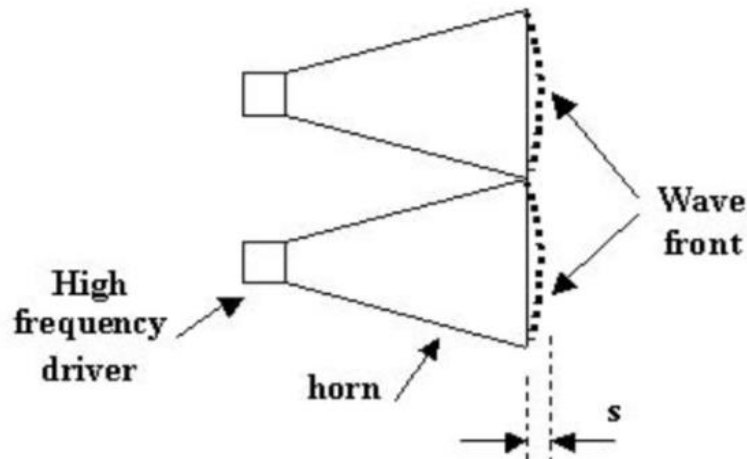

Figure 8 : Side view of 2 horns arrayed. [1]

Designing a waveguide requires the following data:

- Throat diameter of the high frequency driver;
- Vertical coverage expectation;
- Height of the output (imposed by the cabinet size);
- Width of the waveguide (which is a compromise between energy radiated and horizontal coverage).

Sometimes a horn is coupled to the waveguide in order to increase the level at the low cut-off frequency of the compression driver. The horn (or deflectors, see Figure 9) act as acoustical impedance adapter. Indeed, the loudspeaker, which is a generator of pressure, has a high source impedance. But it drives the air which has a low impedance, because of its low density. This is why the horn (or deflectors) has an increasing cross-section: to decrease the acoustical impedance of the pressure that the loudspeaker applies. [5]



Figure 9 : Deflectors in front of the waveguide output.



Finally, the sum of individual waveguide (or horn) areas must be higher than 80% of the vertical frame of the array. Thus, it should be possible to calculate the maximum vertical cabinet size.

#### 2.4. Reasons for Controlling the Directivity

It is important to control the directivity of a speaker in order to avoid comb filtering, that means avoiding secondary lobes. On Figure 10, there is a space with 2 loudspeakers. One is approximately 3,4m away from the listener and the other is 3,75m away. Then the difference path is 1ms at the sound speed.

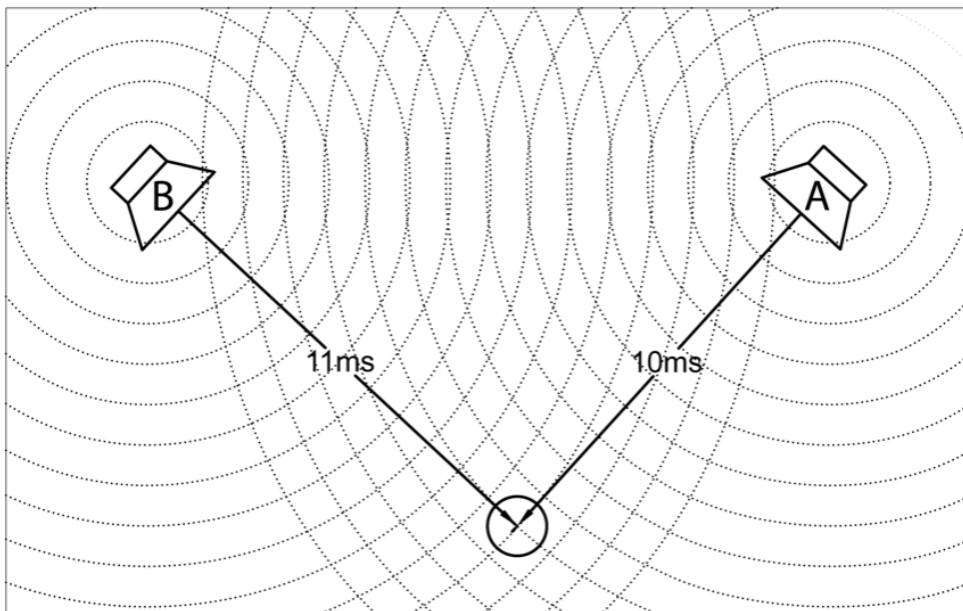

Figure 10 : 2 loudspeakers radiating towards a listener at the "X" position. [6]

At 500 Hz (Figure 11), this is a  $180^\circ$  phase shift. This results as a destructive interference. However, at 1 kHz (Figure 12), this is a constructive interference ( $360^\circ$  phase shift). The resulting frequency response contains many dips (Figure 13). This effect is called « comb filtering ». The phenomenon is not always the result between 2 loudspeakers. Same thing can happen when a sound reflects from a wall in the room and arrives in the same place as the direct sound.

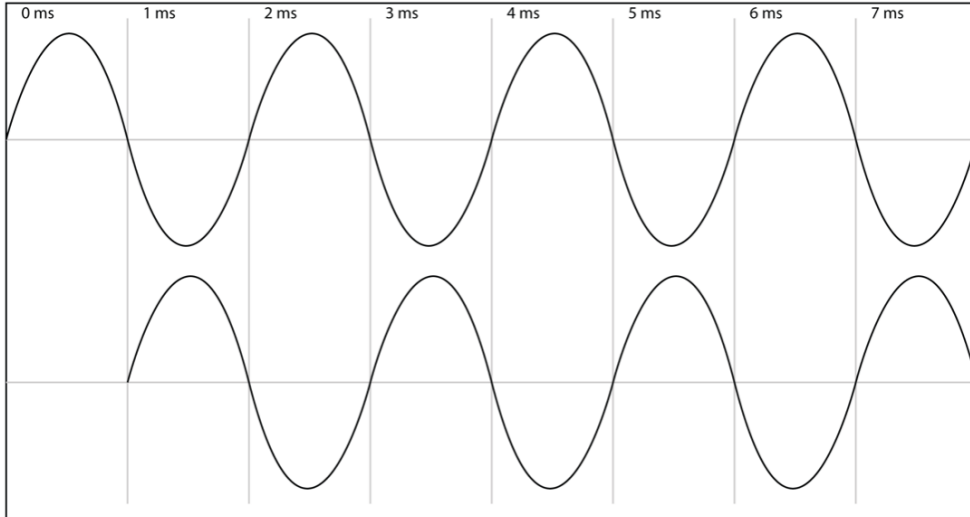

Figure 11 : At 500 Hz, 2 signals delayed by 1 ms give a 180° phase shift. [6]

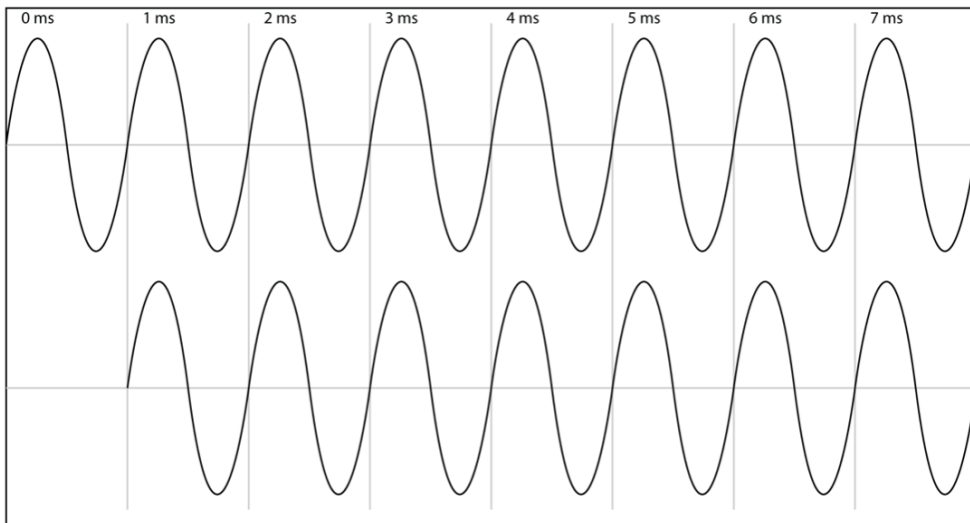

Figure 12 : At 1000 Hz, 2 signals delayed by 1 ms give a 360° phase shift. [6]

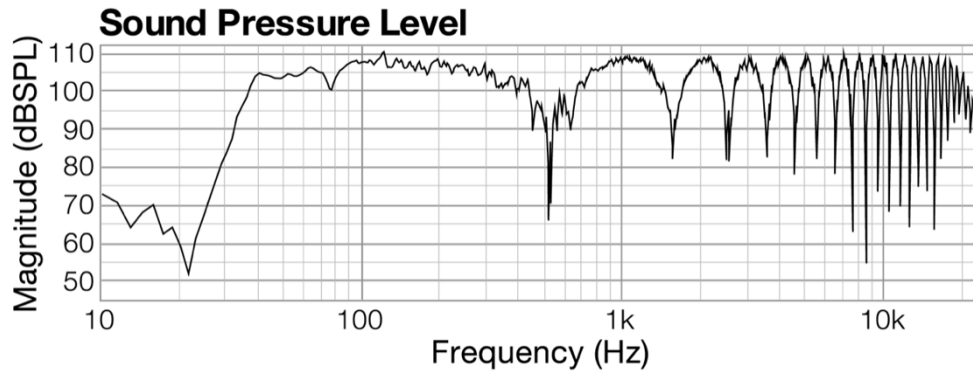

Figure 13 : Resulting frequency response at the "X" position. [6]

There are few ways to avoid comb filtering:

- Using several point sources (with a well-controlled directivity);
- Insert delay on the farthest source or reduce the sound pressure level of one;
- Move away the sources from any reflecting surface (ground, walls, ...);
- Controlling the directivity of each source, that means avoiding secondary lobes.

## 2.5. Methods Used to Control The Directivity

### *Low and mid frequencies*

Improving acoustic coupling allows to avoid secondary lobes. At low and mid frequencies, a phase plug can split the diaphragm into 2 sources (Figure 14). As a result, the distance between 2 sources side by side is shorter. Another way to improve coupling is using diffraction. A sheet which contains slots is placed in front of the loudspeaker. The slots can be directly included in the grid (Figure 14). All these solutions allow to shift the emergence of secondary lobes.



Figure 14 : NEXO GEO M10 (on the left) and AUDIOFOCUS ARES 8 (on the right).

On middle to biggest venues, it is often necessary to decrease the level of very low frequencies on the stage, because musicians do not need so much bass. The solution is to generate a slightly delayed signal by 2 ways:

- Placing a speaker upside down (Figure 15), or
- Inserting a loudspeaker out of phase (Figure 16).

This is called a « cardioid setup » because the resulting polar diagram looks like a heart (Figure 17 and Figure 18).



Figure 15 : Cardioid setup for subwoofers (L-ACOUSTICS SB28).

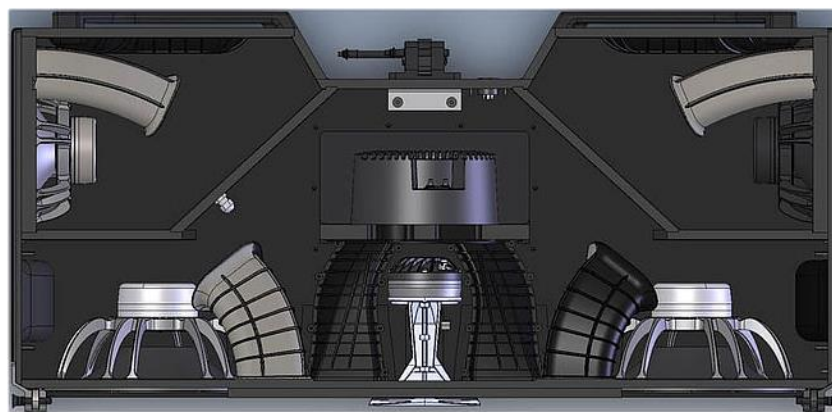

Figure 16 : Loudspeakers on the rear, coupled with a delay, reduce the bass level behind the speaker (D&B GSL-serie). [7]

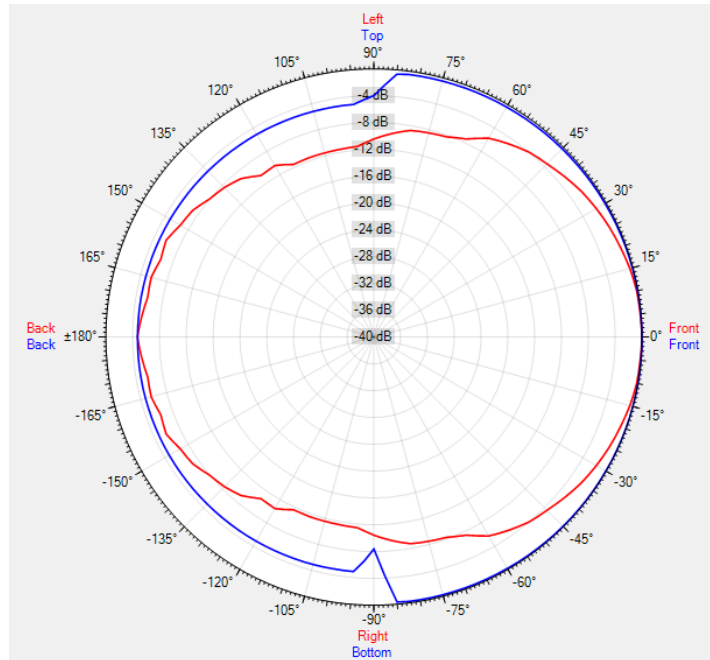

Figure 17 : Polar diagram at 150 Hz of a "basic" line array speaker. Red curve is the horizontal directivity. Blue curve is the vertical directivity.

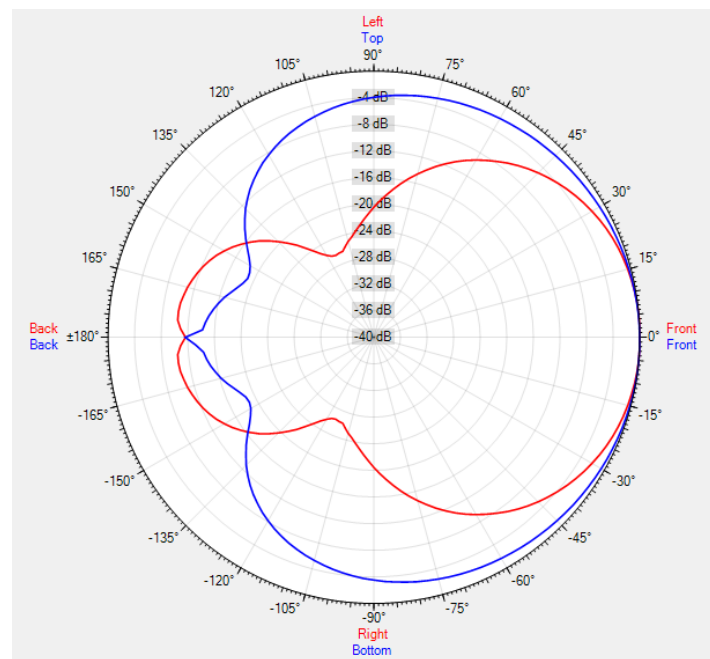

Figure 18 : Polar diagram at 150 Hz of the speaker on the Figure 16. Red curve is the horizontal directivity. Blue curve is the vertical directivity.

### *High frequencies*

At high frequencies, directivity is controlled by the horn and the waveguide. Obviously, the gap between each horn in the array has to be as low as possible. Hence, the critical case is when each box is rigged to the other one at the maximum tilt angle (Figure 19). The maximum tilt angle is often between  $5^\circ$  and  $15^\circ$  for a line array speaker. It is always a compromise of coverage, according to the application. Smallest boxes will have highest vertical coverage in order to cover the largest audience with just few boxes. Bigger audience will require more power, which means bigger boxes and lower nominal vertical coverage.

Few manufacturers create 2 versions of their products: narrow (or focus) and wide (Figure 20). Thus, the horizontal coverage is adapted to the venue for many reasons (distance between arrays, walls near arrays ...).



*Figure 19 : Array of 5 boxes (ALCONS LR7) with the maximum tilt angle between each box.*

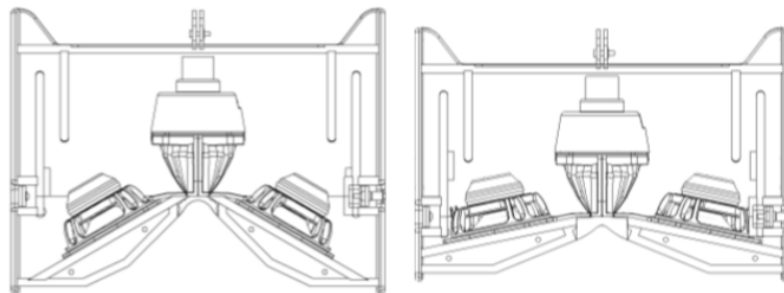

*Figure 20 : APG UC206 NARROW (on the left) and WIDE (on the right).*

### ***Crossover frequency***

The filter sorts frequencies according to the target bandwidth of each loudspeaker. It can be passive or active. A passive filter contains resistors, capacitors and inductors. These components have to be quite strong since the passive filter receives the signal amplified by the amplifier. The last problem is about slope at target cut-off frequencies. In a passive filter, the slope depends on the number of capacitors. More capacitors means steeper slope. One capacitor implies a -6 dB/octave slope. In order to avoid secondary lobes, the slope has to be very steep. But it would be quite expensive to add a lot of capacitors, without regard to the additional weight.

The active filter contains smaller components because it is placed just before the amplifier. Moreover, it avoids the problem of variable impedance of the loudspeakers. The active filtering can be analogic or digital. The active filter (especially the digital one) allows to quickly adapt the filtering to the application, since the parameters can be easily changed (cut-off, frequency, slope, delay, ...). There are 2 kinds of digital active filtering: IIR and FIR. The FIR filter is the only one which keeps the phase linear (no phase shift), that means the best to control directivity. But it is also the more expensive.

Gradually, active filtering supersedes passive filtering. But few major manufacturers still use passive filtering. Soon, digital filtering should be the standard.

## **3. Analysing Directivity**

### **3.1. Setup**

Isobar diagrams allow to easily identify directivity problems. The diagram contains 2 axes: angle axis and frequency axis. The distance of the virtual microphone is fixed (5 meters away). The resolution is as high as possible (2,5°). Colours indicate the loss of sound pressure level against the axis. It is possible to analyse the directivity in the horizontal and the vertical planes. Simulations have been realized with the "EASE GLL Viewer" software from AFMG. GLL files are generated by measuring 1 (or several) speaker(s) in an anechoic chamber. The speaker is fixed to a robotic arm and a microphone measures the frequency response at different positions. GLL files are available on the manufacturer's website.

### 3.2. Psychoacoustic Considerations

Before analysing isobar diagrams, it is important to give some clarifications about hearing acuity. The first one is about the sound pressure level. A gain of 3 dB is equal to a sound pressure doubling. However, most of people get the impression that the level has doubled while the gain is between 8 to 10 dB. In datasheets, directivity is often given for a 6 dB loss.

Often, it is not necessary to have a good directivity up to 16 kHz. As human hearing perceives high frequencies louder than bass, a progressive drop-off after 2 kHz is recommended while setting a sound system [8]. At 10 kHz, the loss should be around 9 dB. Furthermore, hearing acuity evolves over time (Figure 21). Also, detection of anomalies depends on the gain and the width of the anomaly (Figure 22). Curves are offset for clarity.

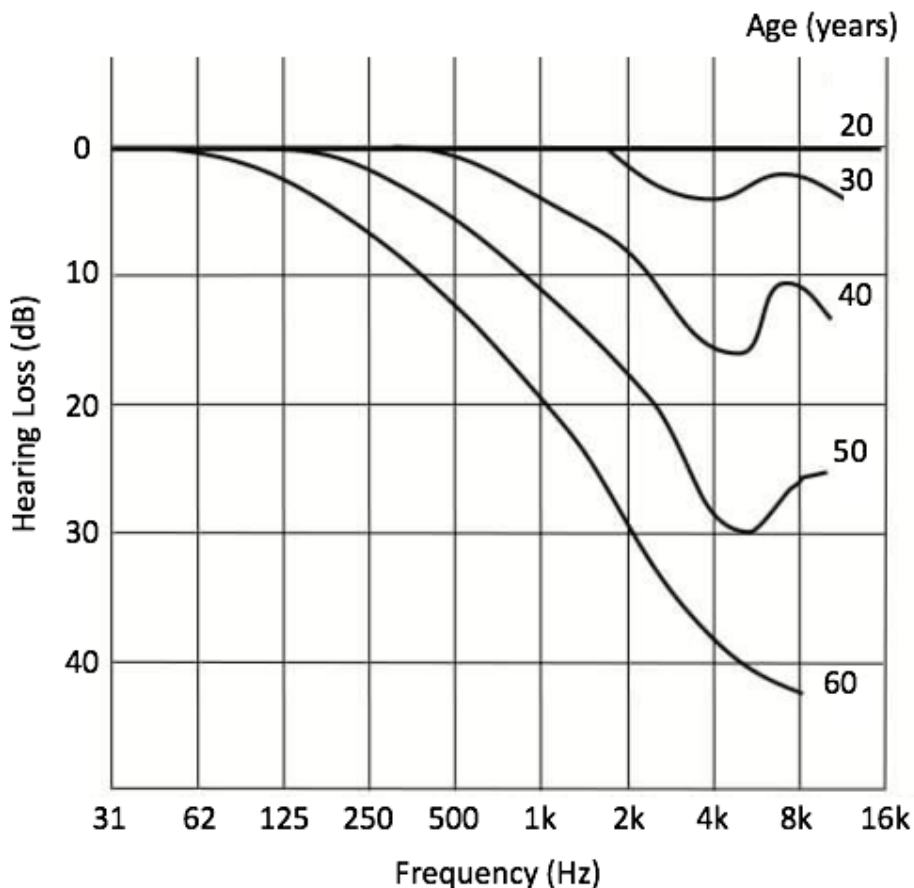

Figure 21 : Hearing loss according to the age. [9]



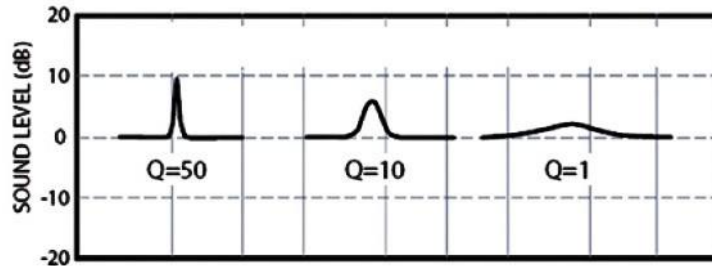

Figure 22 : Detection thresholds for high, medium and low  $Q$  variations. [10]

### 3.3. Examples of Isobar Diagrams

The first example of isobar diagram is about a 2-way line array speaker (Figure 23). The first way contains one 8 inches loudspeaker each side. The second way is equipped with few compression drivers and a waveguide. The horizontal directivity (Figure 28) is not well controlled. There is a huge loss around 600 Hz which comes from the oversized gap between the 8 inches loudspeakers. Loss in the voice frequency range (mainly 100 to 4000 Hz) is especially annoying. Directivity below 125 Hz is not important because it is omnidirectional (since wavelengths are very high). Loss at low frequencies is due to reflections in the anechoic room.

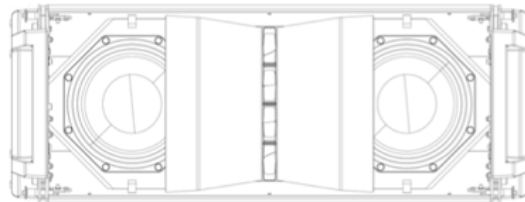
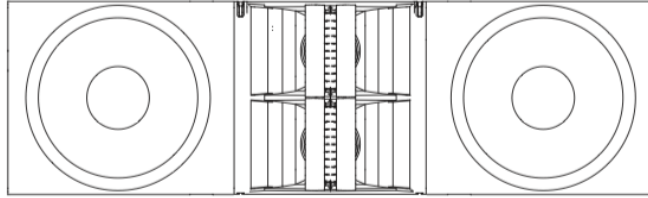

Figure 23 : Front view of the first speaker analysed.

The second example is a 3-way line array speaker (Figure 24). That means the first way (2 big loudspeakers) reproduce bass frequencies. The second way contains mid frequencies drivers. The third way is equipped with 2 compression drivers and waveguides. This speaker is designed for very long throw. Thus, the directivity is analysed at 20m away (Figure 29). Once again, horizontal directivity is problematic. The problem is also due to the high gap between loudspeakers. Moreover, the passive filter does not improve the directivity control. Crossover frequencies are clearly visible (300 Hz and 2 kHz). Active filtering should smooth the dips at the crossover points.



*Figure 24 : Setup of the second speaker analysed.*

The third example is a point source speaker (Figure 25) with active filtering. The speaker is a column composed of 4 small loudspeakers for mid frequencies and 1 driver (with waveguide and horn) for high frequencies. This kind of speaker allows to cover a small audience without using line array. As the width is very low, the horizontal directivity is high and homogeneous (Figure 30). But the vertical directivity is not as smooth. Indeed, there is a huge secondary lobe around 800 Hz (Figure 31 and Figure 32). This speaker will be used alone since this is a column. Thus, secondary lobes can be really annoying if listeners are out of the vertical nominal coverage (about  $18^\circ$  for -6 dB). Actually, 800 Hz is the crossover frequency. Because of this layout, the frequency crossover should be lower to avoid this problem. But a lower crossover frequency means a bigger displacement for the high frequencies driver. Thus, it should be necessary to use a driver with a bigger membrane. Obviously, a larger driver is more expensive.

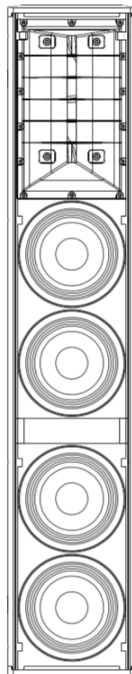

*Figure 25 : Setup of the third speaker.*

The fourth example is a 3-way point source speaker (Figure 26). The filtering is passive. Overall, horizontal and vertical directivity are well-controlled (Figure 33 and Figure 34) despite a very little dip around 2 kHz, because radiating sources are as close as possible.



*Figure 26 : The fourth speaker analysed.*

The last example is a 2-way point source speaker (Figure 27). The first way is just composed of a twelve inches loudspeaker. The second way is composed of a driver and a horn (no waveguide). The filtering is active (digital). Horizontal and vertical directivity (Figure 35 and Figure 36) are huge and highly homogeneous, because there is a simple horn in front of the high frequency driver. The directivity has not to be over-controlled since this point source is designed to be used alone and for various applications.



*Figure 27 : The fifth speaker analysed.*

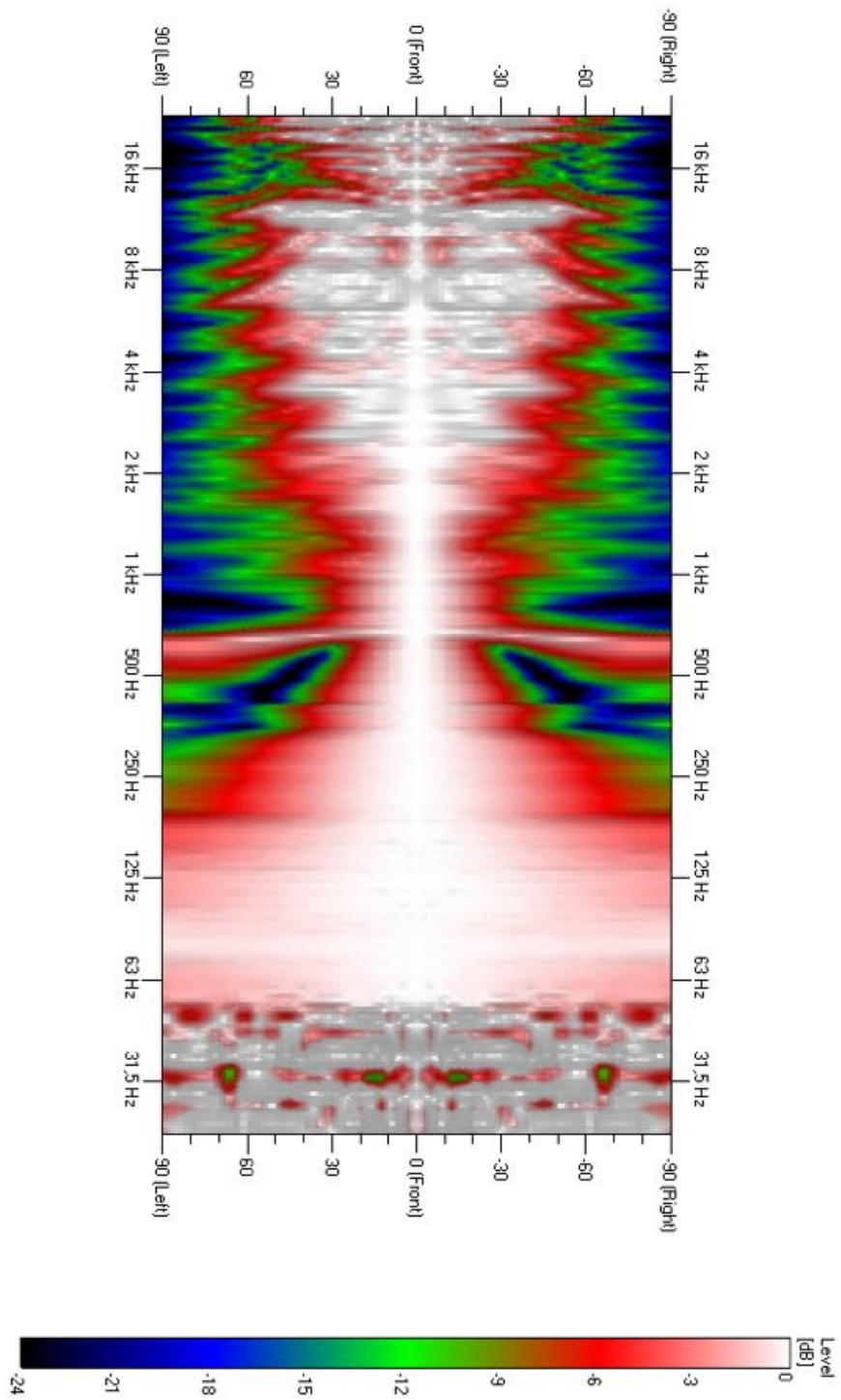

Figure 28 : Horizontal directivity of the first speaker 5m away.

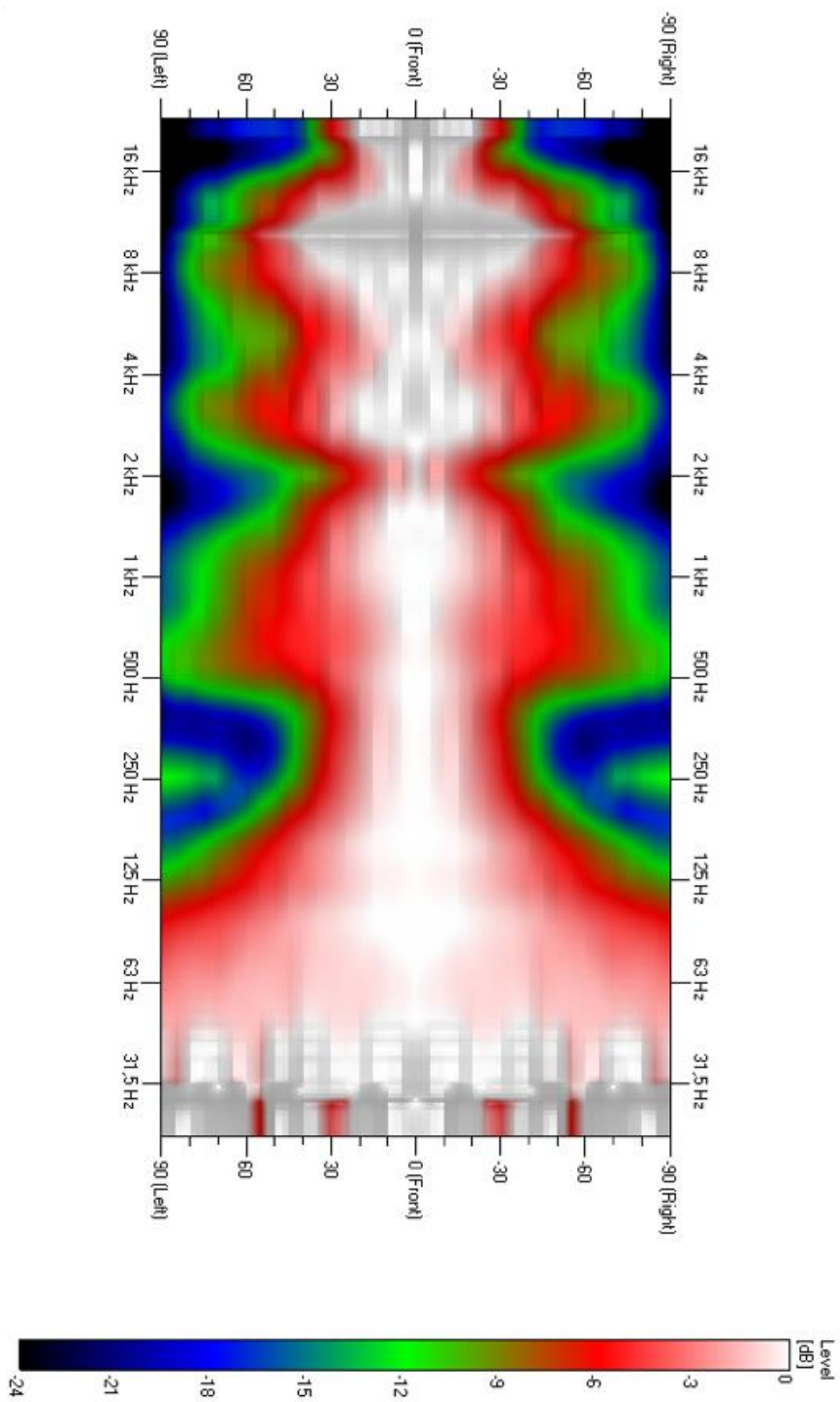

Figure 29 : Horizontal Directivity of the second speaker 20m away.

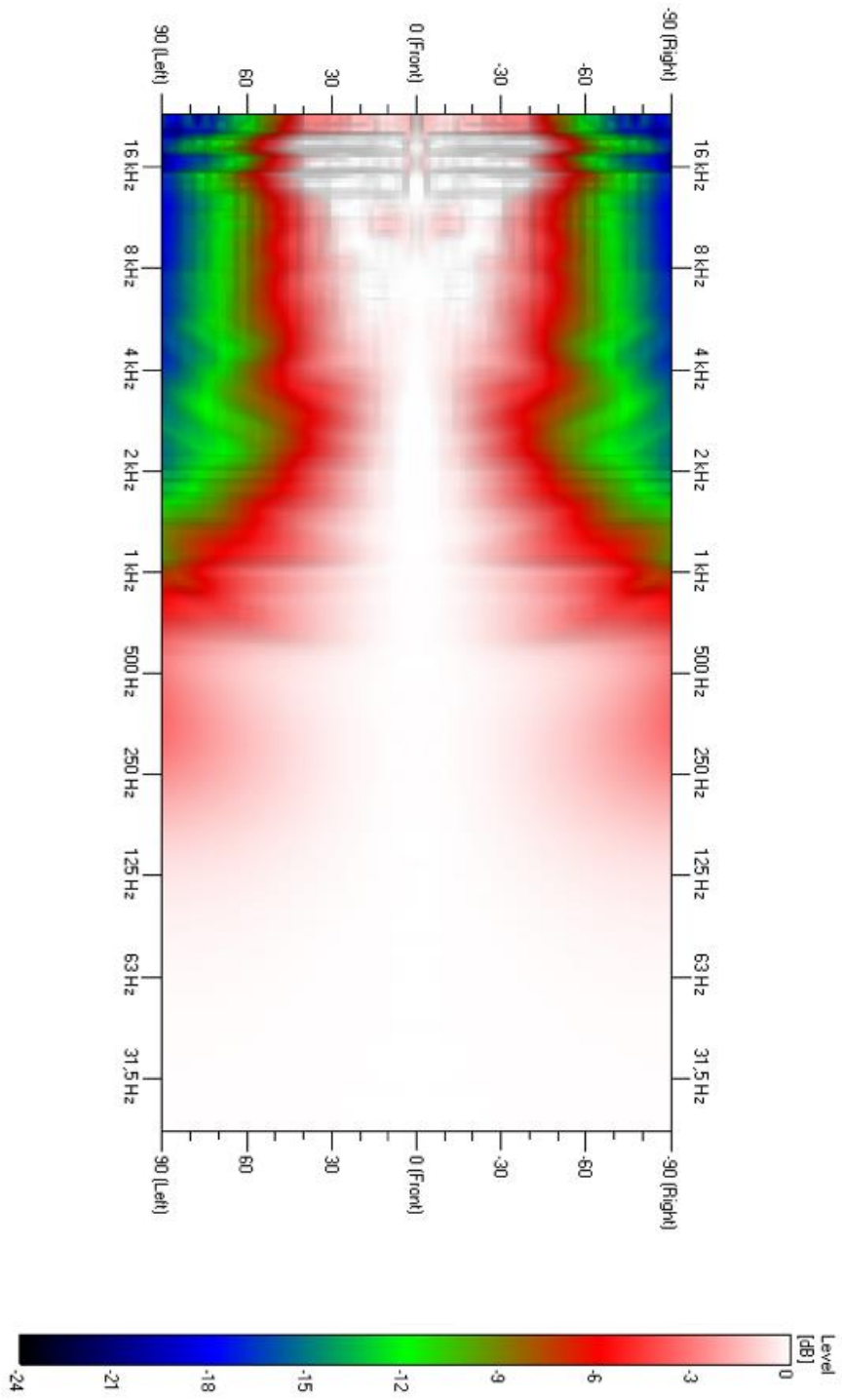

Figure 30 : Horizontal directivity of the third speaker 5m away.

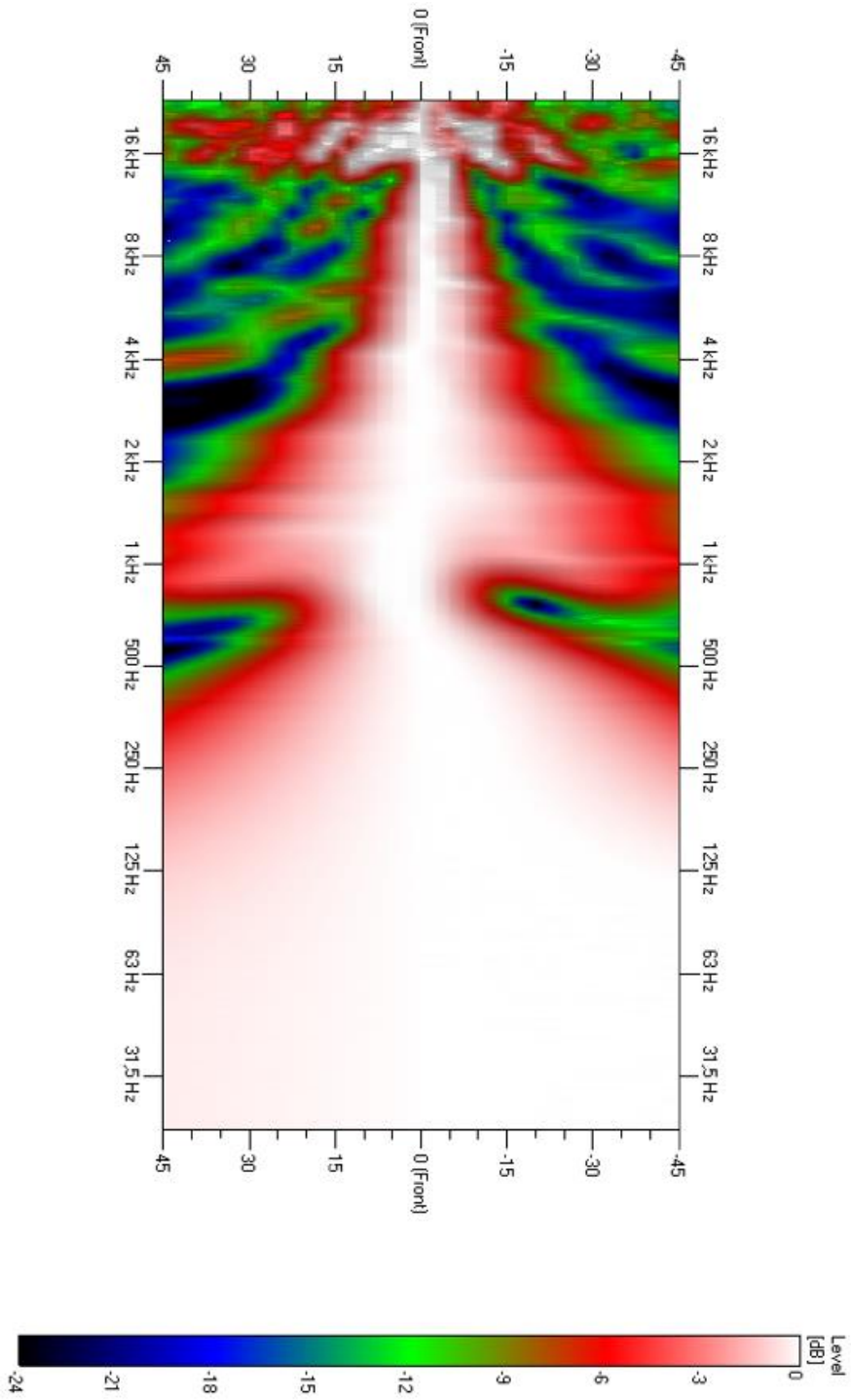

Figure 31 : Vertical directivity of the third speaker 5m away.

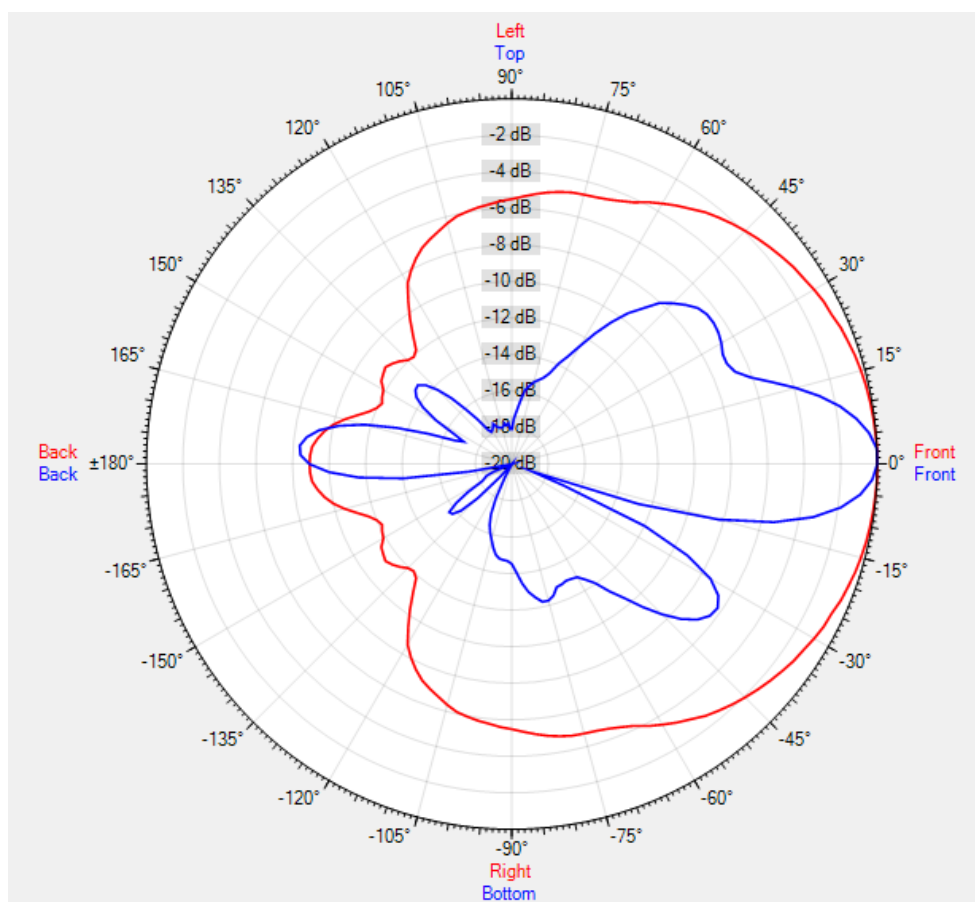

Figure 32 : Polar diagram of the third speaker at 800 Hz 5m away. Red curve is the horizontal directivity. Blue curve is the vertical directivity.



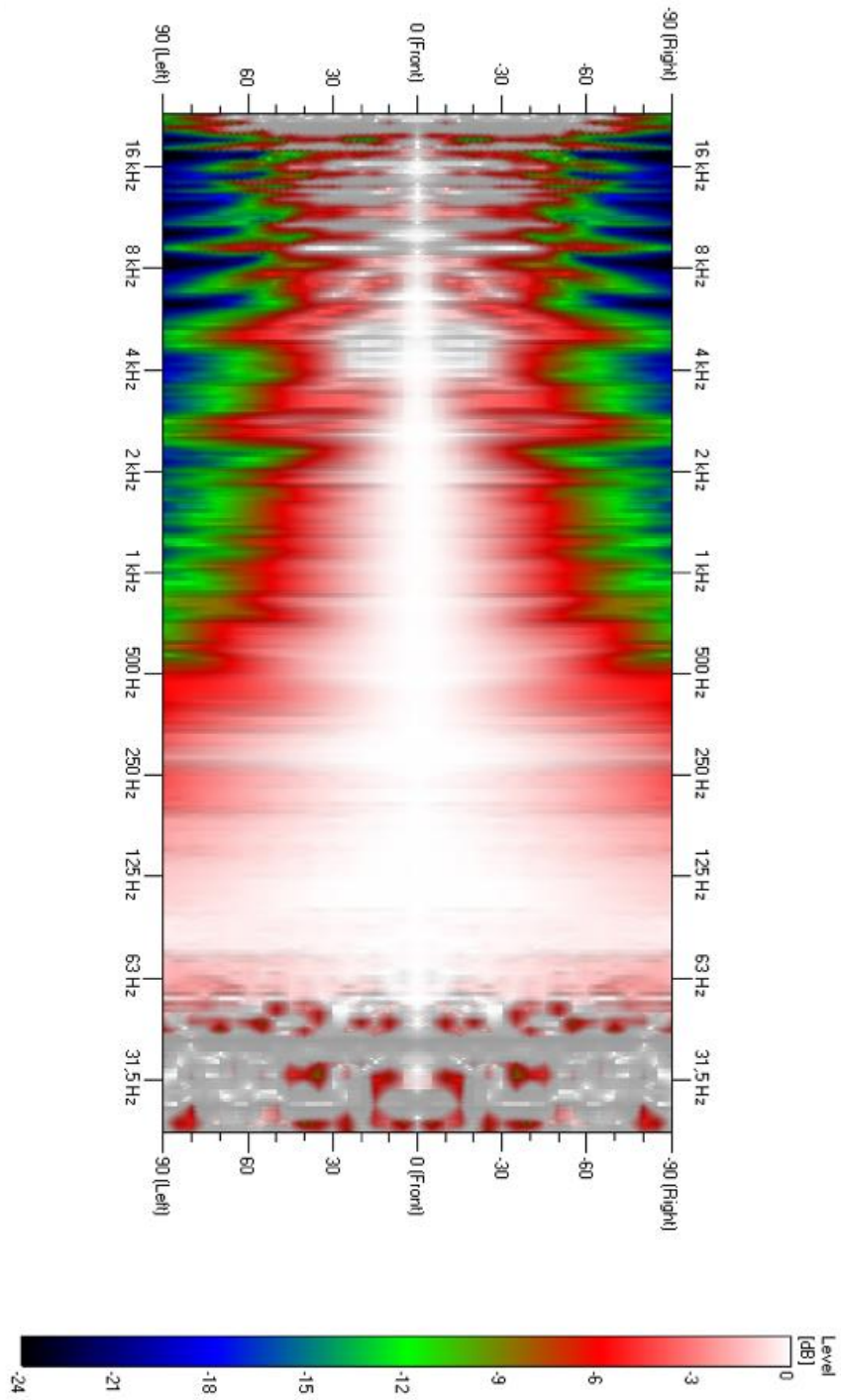

Figure 33 : Horizontal directivity of the fourth speaker 5m away.

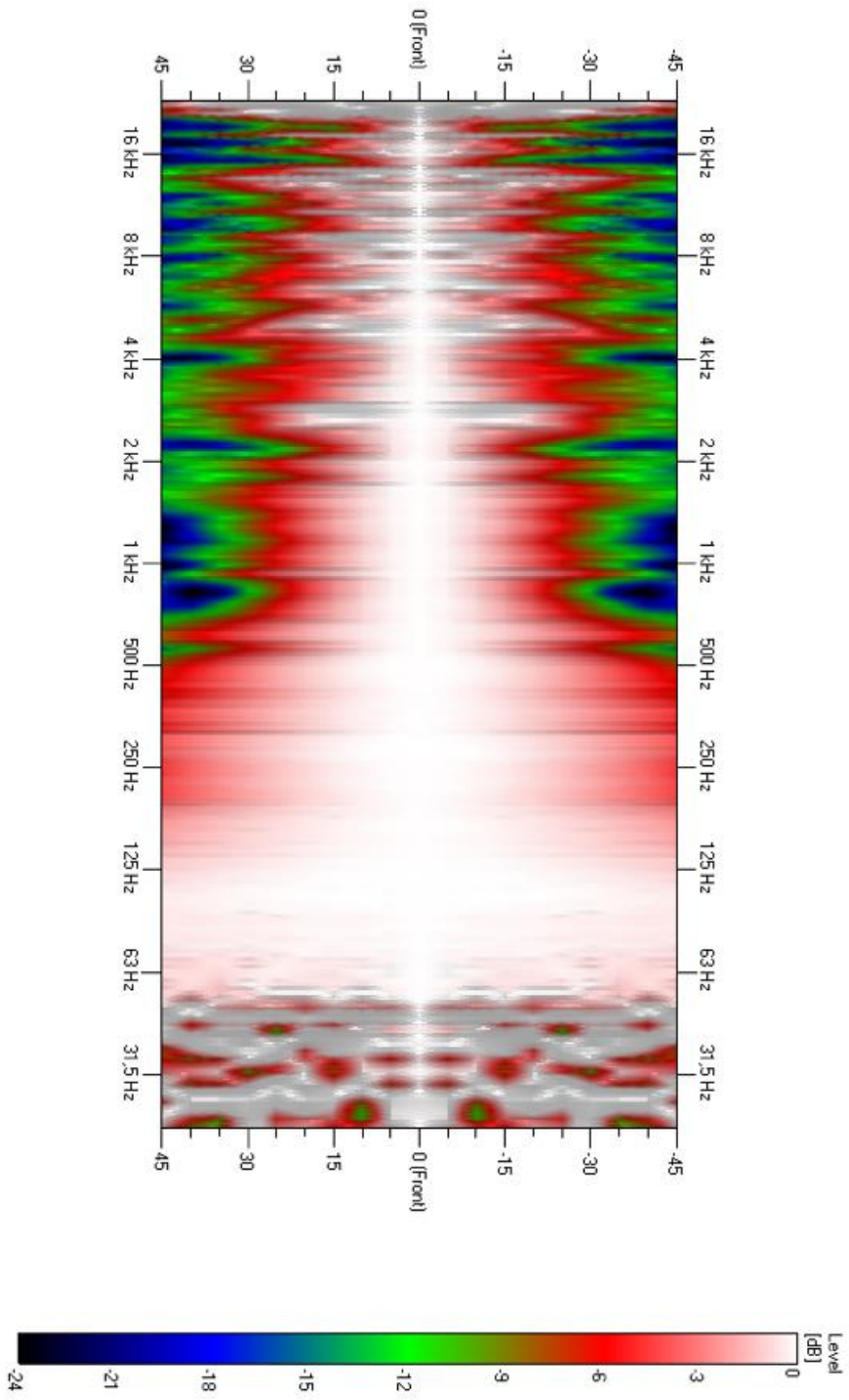

Figure 34 : Vertical directivity of the fourth speaker 5m away.

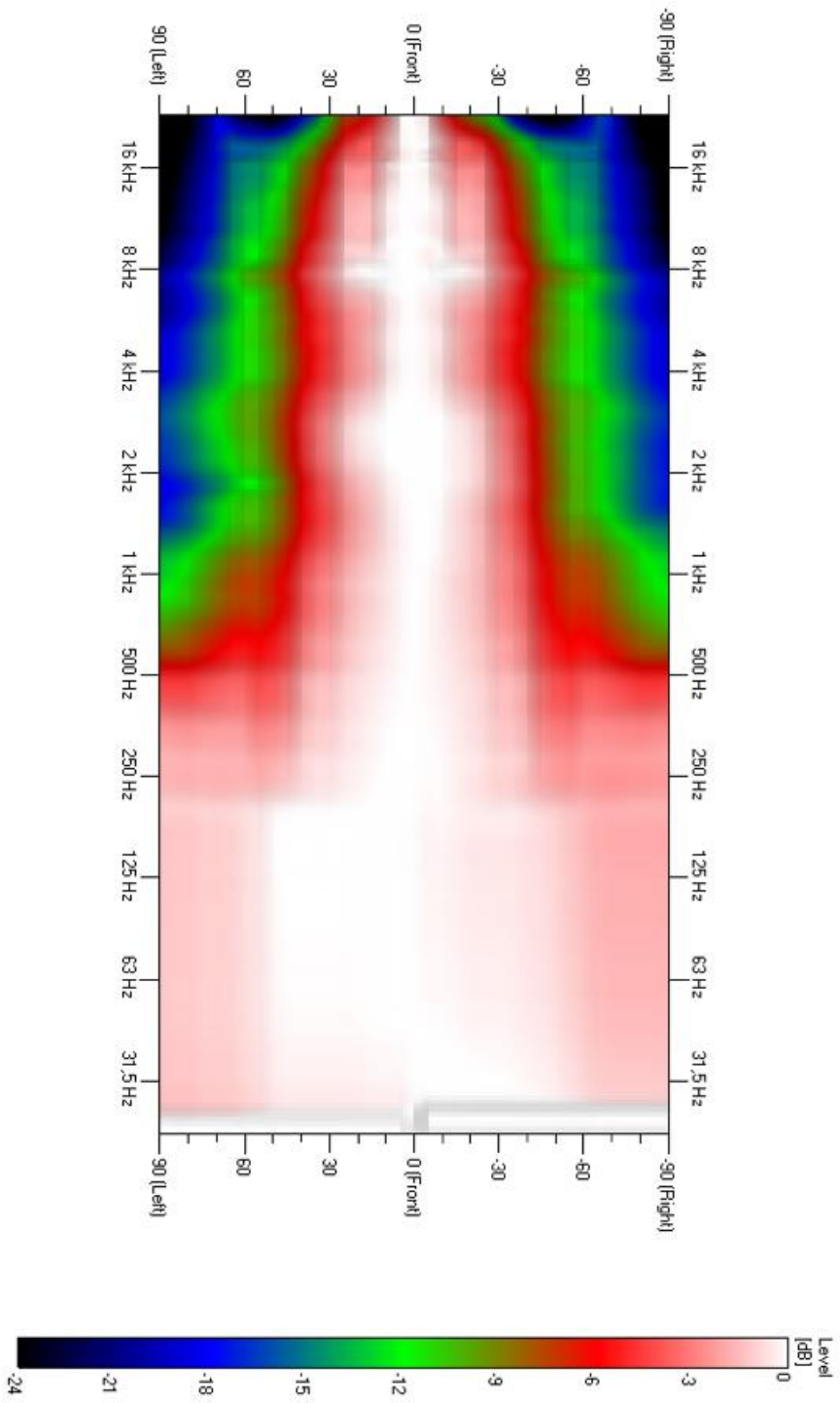

Figure 35 : Horizontal directivity of the fifth speaker 5m away.

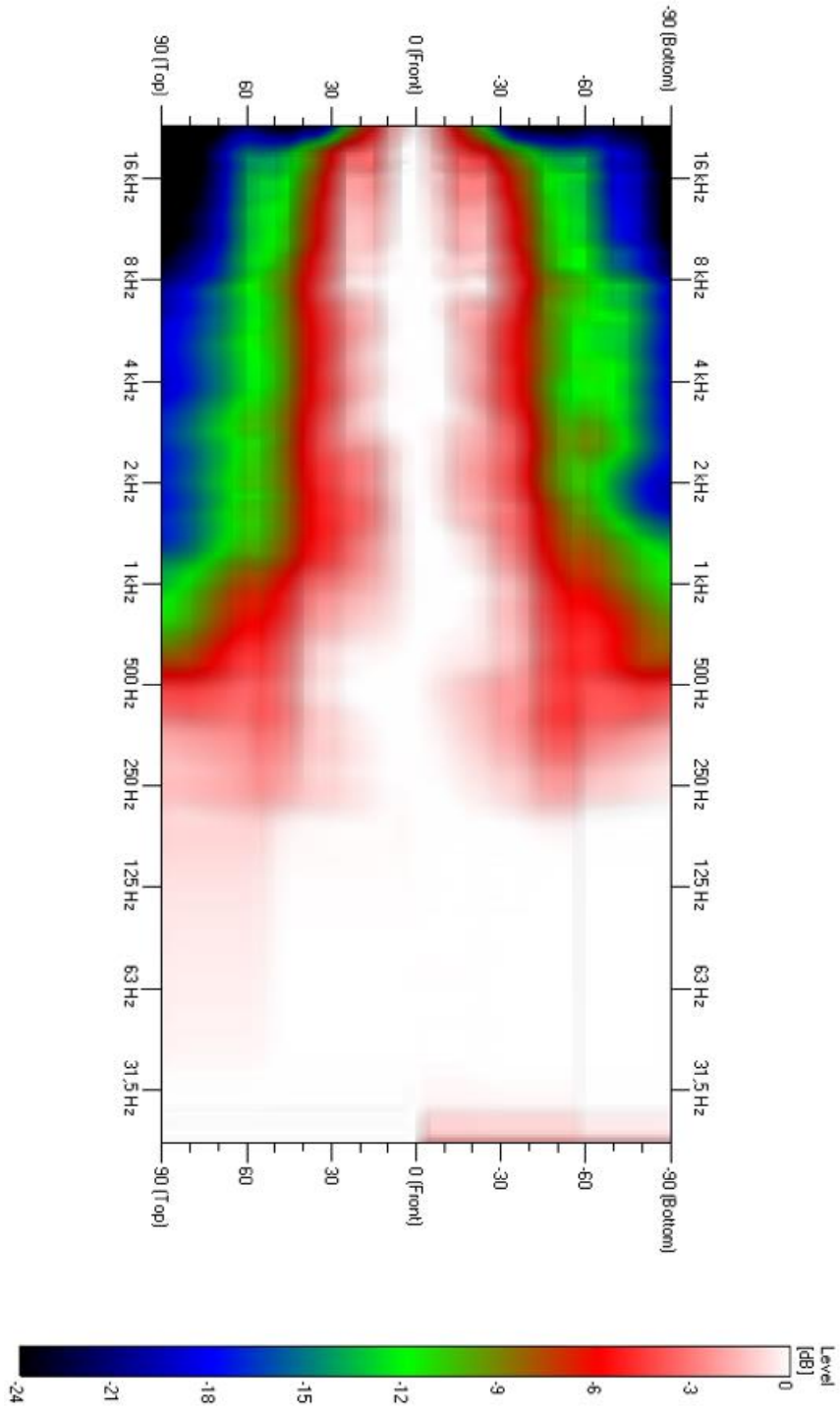

Figure 36 : Vertical directivity of the fifth speaker 5m away.

## 4. Choice Between Line Array and Point Source

It is quite difficult to control the vertical directivity in a very narrow angle. Thus, it is interesting to analyse the directivity of a line array composed of several boxes. In this example, the speaker used has 2 ways. The first way contains one 8 inches loudspeaker each side (layout of Figure 23). The second way is equipped with one compression driver and a waveguide (coupled with a horn). The array is composed of 5 boxes, 5 meters above the floor (Figure 38). Obviously, there is an array each side of the stage. In addition, few boxes are placed on the stage floor to increase the sound pressure level on the first ranks. This kind of setup is common for small areas.

As the array is quite small, there is not the Intermediate Field where the sound pressure level decreases by 3 dB while the distance is doubled. The gain of each box has been adapted to improve homogeneity (Table 1). On the other hand, it is important to keep an acoustic coherence. That means the sound pressure level should be lower for people far from the stage. Typically, a maximum loss of 6 dB is very good. Tilt angles have been chosen so that the maximum level difference between 4m and 20m is 7 dB (Figure 39 and Figure 40). The frame is inclined of  $7^\circ$ . In practice, it is really hard to satisfy this criterion all over the audience because of humidity (Figure 37), reflections, crowd noise, ...

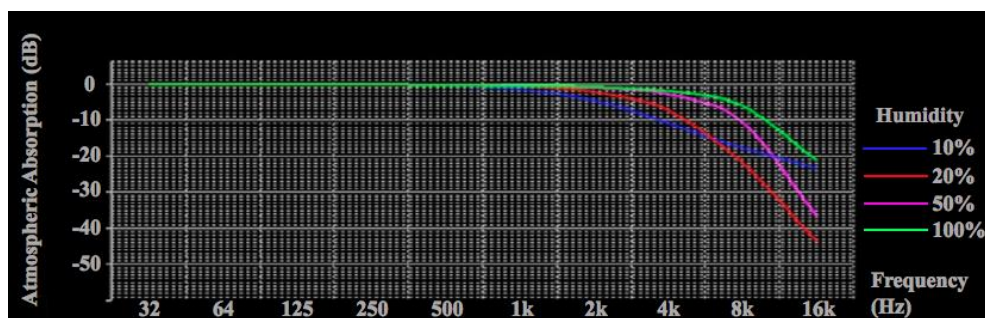

Figure 37 : Atmospheric absorption according to the humidity. [11]



Figure 38 : Setup of the example.

Box number	Gain (dB)	Tilt angle (°)
1	2	0
2	0	2
3	-3	2
4	-6	4
5	-9	7

Table 1 : Gain and tilt angle for each box of the array.

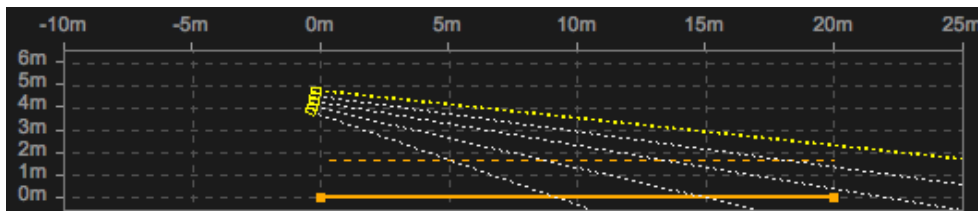

Figure 39 : Side view of the setup. The continuous line represents the ground of the venue. The orange dotted line represents the height of the listening position (around 1,70 m).

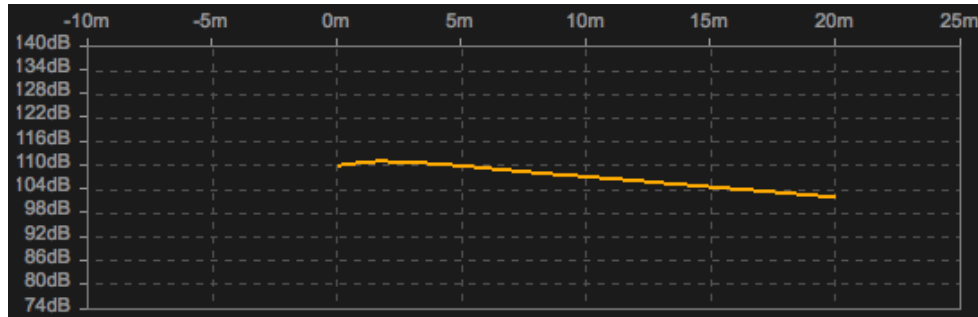

Figure 40 : Estimated sound pressure level according to the distance for a broadband IEC60268 signal.

The horizontal directivity is not analysed because it is nearly the same as one box. The vertical directivity has been analysed at three listening points (Figure 41, Figure 42 and Figure 43). Position of the listener has been estimated geometrically.

Farther is the listener, flatter is the response. That means the coupling looks better far from the array, there are less sound pressure level loss. Indeed, while the listener is closer to the array he can « hear the gap » between each box. But the problem is the same with every line array: interference. This is why few manufacturers decided to develop large point source speaker which can be used alone. The biggest advantage of the line array is the Intermediate Field.

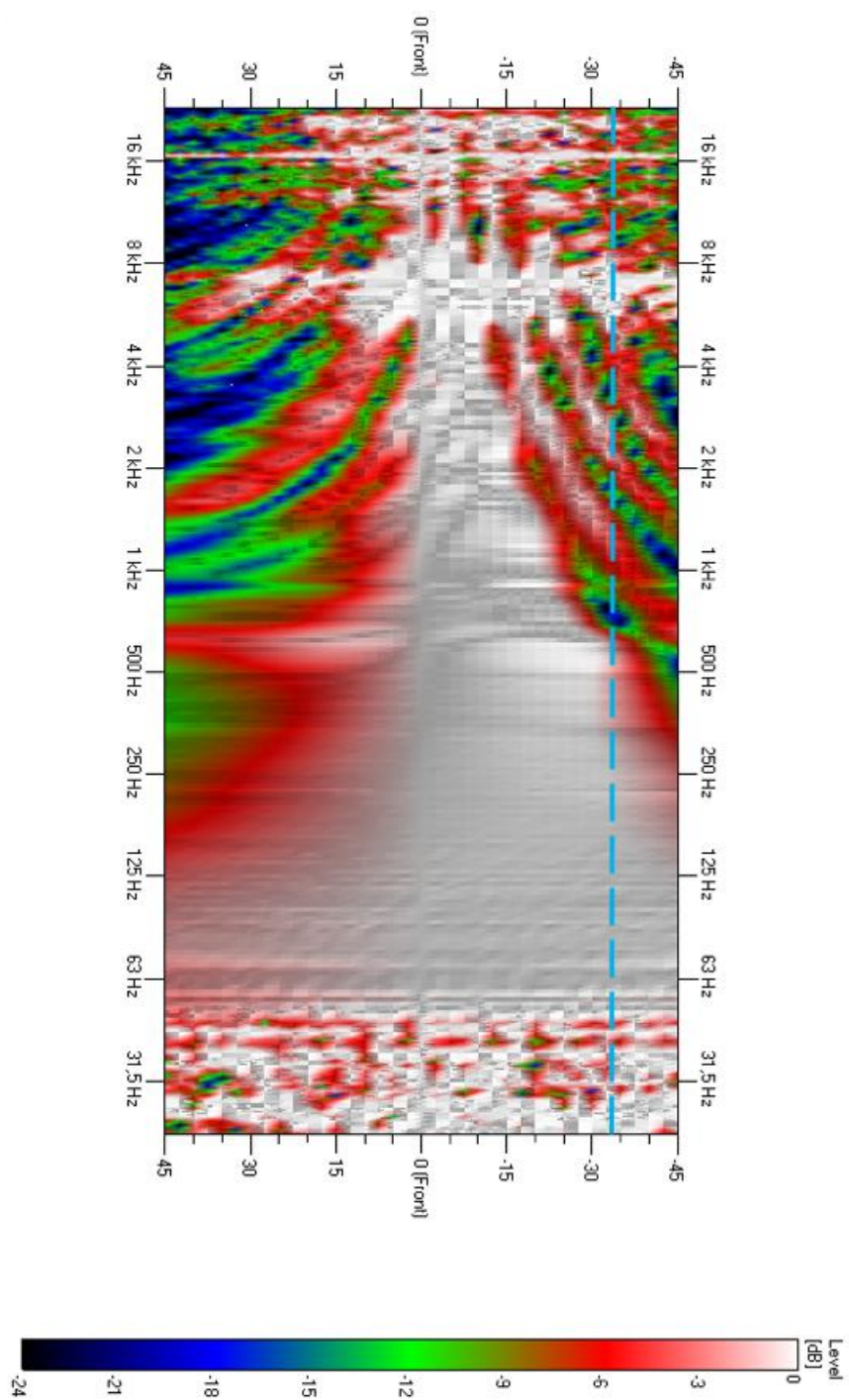

Figure 41 : Vertical directivity of the array 5m away. The frequency response at the listeners position is marked by the dotted blue line.



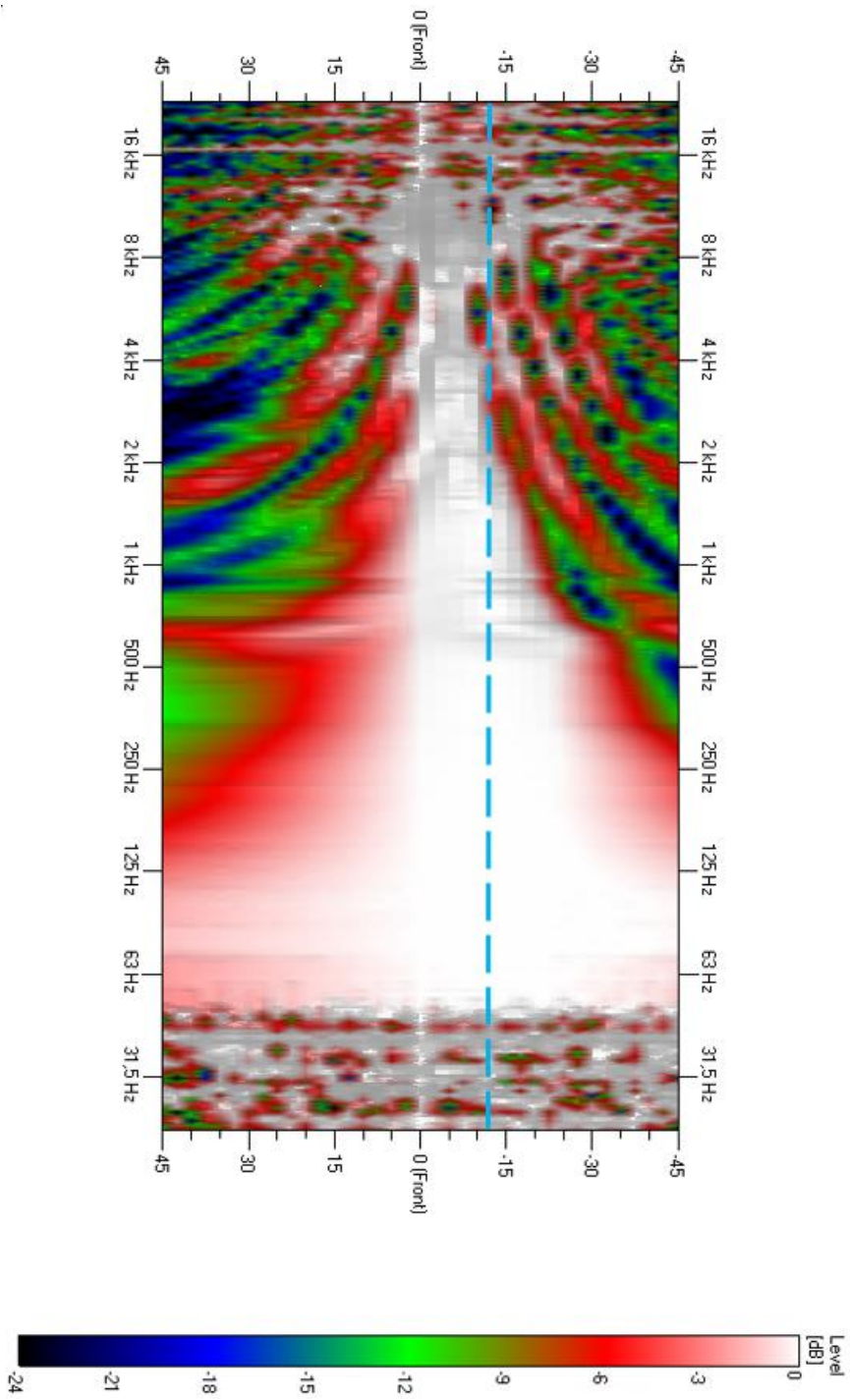

Figure 42 : Vertical directivity of the array 10m away. The frequency response at the listeners position is marked by the dotted blue line.

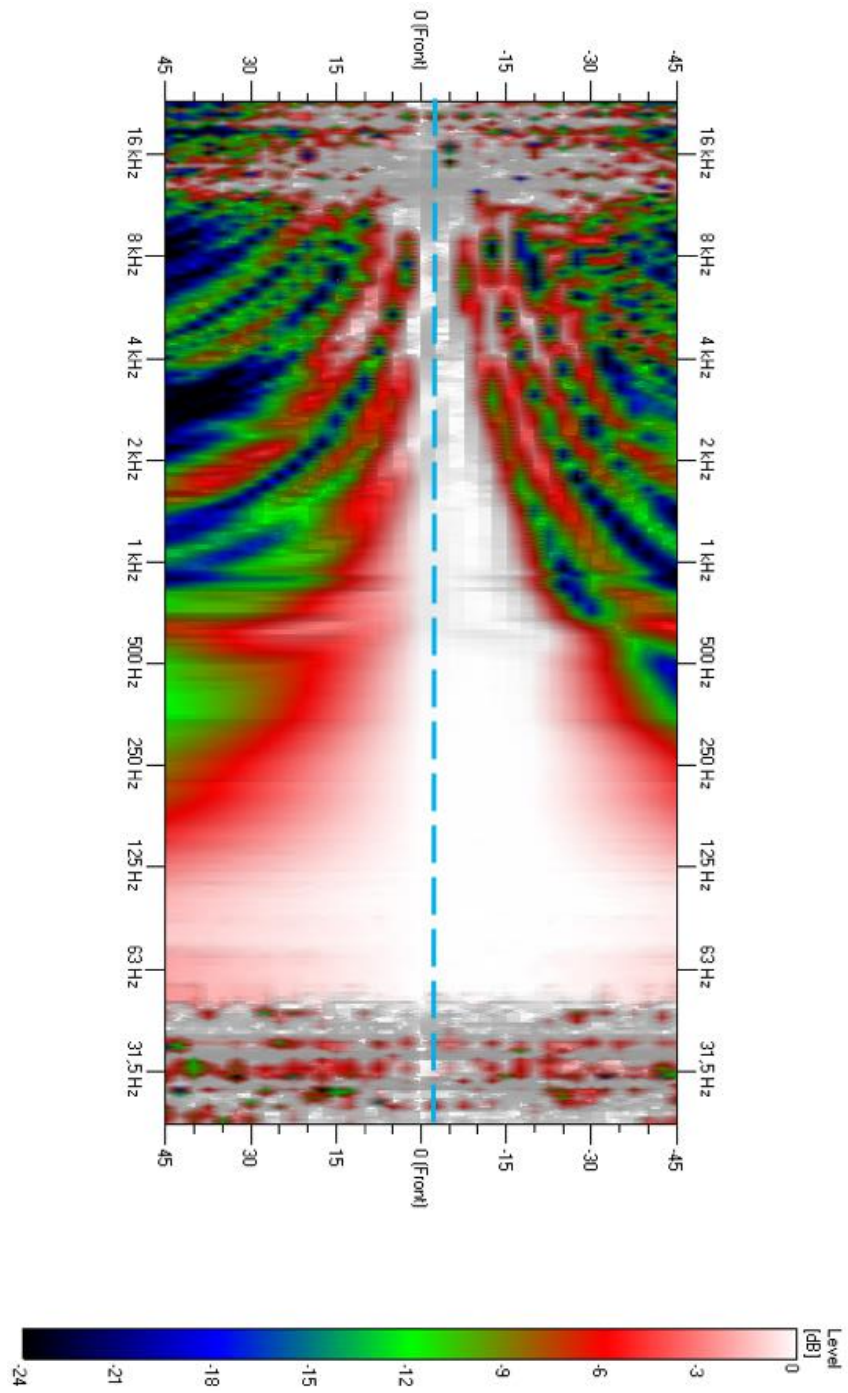

Figure 43 : Vertical directivity of the array 20m away. The frequency response at the listeners position is marked by the dotted blue line.

## 5. Quality of a speaker

It is important to understand that a wide horizontal coverage is not still suitable. Most important about directivity is homogeneity and intelligibility. Indeed, in a very reverberant space (a church for example) a narrow directivity is suitable in order to decrease reflections. Directivity is not the only criteria to characterize the quality of a speaker. Moreover, it can be different according to the application. Most widespread acoustic criteria are:

- Frequency response;
- Directivity;
- Maximum sound pressure level;
- Distortion.

There is distortion while the original signal is modified. Distortion is quite global because it comes from different sources: loudspeakers, enclosure, amplifier, the room, etc.

As explained in the examples, it is hard to obtain a well-controlled directivity. Furthermore, designing a speaker requires knowledge about psychoacoustic and human hearing acuity. Because our ears are the last actor in the process.

## 6. Sources

- [1] URBAN, M., HEIL, C., BAUMAN, P., *Wavefront Sculpture Technology*  
Audio Engineering Society, 51, 2003 October, pp. 912-932.  
URL: <https://www.l-acoustics.com/fr/a-propos/domaines-de-recherche/>
- [2] PIETQUIN, D., (updated in May 2007), *Sources sonores*.  
URL: <https://www.techniquesduson.com/sourcessonores.html>
- [3] DI COLA, M., *et al. Design and Optimization of High Directivity Waveguide for Vertical Array*  
Audio Engineering Society, 127th Convention, 2009 October, pp. 1-14.
- [4] AUDIO TECHNOLOGY, (edited in February 2017), *Bose DeltaQ ShowMatch Touring PA*.  
URL: <https://www.audiotechnology.com/features/bose-showmatch-deltaq-review>
- [5] KOLBREK, B., *Horn Theory : An Introduction, Part 1*  
Audioexpress, 2008.  
URL: <https://www.grc.com/acoustics/an-introduction-to-horn-theory.pdf>

- [6] DIGITAL SOUND & MUSIC, (edited in May 2011), *Sound Perception & Acoustic*.  
URL: <http://digitalsoundandmusic.com/chapters/ch4/>
- [7] D&B AUDIOTECHNIK, *SL-serie (System Profile)*.  
URL: <https://www.sl-series.com/global/en/system-profile/gsl8-gsl12/>
- [8] MARC, O. (created in 2009), *Calage Sono*.  
URL: [http://hornplans.free.fr/calage\\_sono.html](http://hornplans.free.fr/calage_sono.html)
- [9] HOLCOMBE, A., (created in 2014), *Understanding PRESBYCUSIS*.  
URL: [http://www.psych.usyd.edu.au/staff/alexh/teaching/auditoryTute\\_2014/](http://www.psych.usyd.edu.au/staff/alexh/teaching/auditoryTute_2014/)
- [10] D'APPOLITO, J., *Testing Loudspeakers : Which Measurements Matter, Part 1*  
Audioxpress, 2016 November.  
URL: <https://www.audioxpress.com/article/testing-loudspeakers-which-measurements-matter-part-1>
- [11] DELQUIGNIES, M., « Atmospheric Absorption », in: *Electroacoustic Seminar*,  
under the direction of d&b audiotechnik, Paris, France, 2019, pp. 1–87.